

CARACTÉRISTIQUES

- Standard avec cuve, fouet, palette et crochet.
- 3 vitesses.
- Machine robuste.
- Transmission mécanique.
- La machine doit être arrêtée pour le changement de vitesse.

FEATURES

- Standard with bowl, whip, flat beater and hook.
- 3 gears.
- Robust machine.
- Mechanical transmission.
- The machine has to be stopped to change gears.

EIGENSCHAPPEN

- Standaard met kuip, klopper, vlinder en haak.
- 3 snelheden.
- Robuste machine.
- Mechanische overbrenging.
- Machine moet gestopt worden om van snelheid te veranderen.



Standard avec cuve, fouet, palette et crochet.
Standard with bowl, whip, flat beater and hook.
Standaard met kuip, klopper, vliinder en haak.

3 vitesses.
3 gears.
3 snelheden.

Mouvement cuve.
Bowl operation.
Kuipverplaatsing.

SM-100C/200/200C



Levier.
Handle.
Hendel.

SM-500C



Manivelle.
Handle wheel.
Draaiwiel.

Machine robuste.
Robust machine.
Robuste machine.

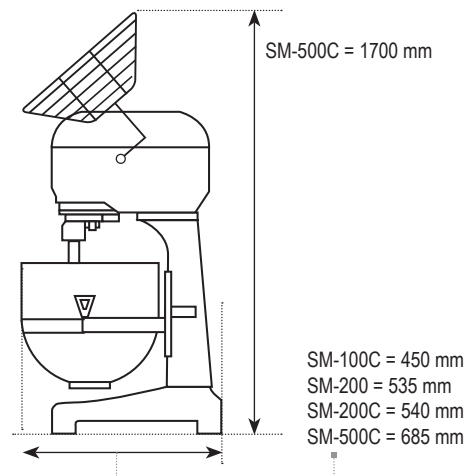
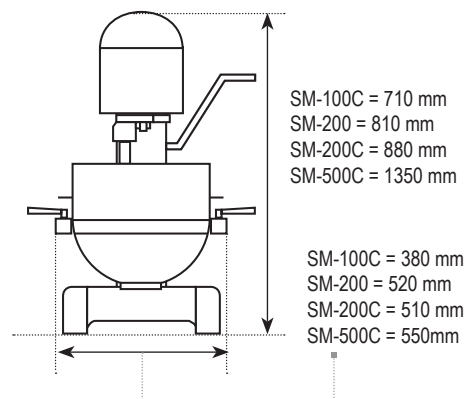
VUE LATÉRALE | SIDE VIEW | ZIJAAZICHT

VUE DE FACE | FRONT VIEW | VOORAANZICHT

MODEL	SM-100C	SM-200	SM-200C	SM-500C
CAPACITÉ CAPACITY CAPACITEIT (L)	10	20 (10 opt.)	20 (10 opt.)	40 (20 opt.)
PUISSANCE MOTEUR MOTOR POWER MOTORVERMOGEN	0,25 kW	0,9 kW	0,9 kW	1,2 kW
Trs/Min à 50 Hz R.P.M. at 50 Hz Omw/min bij 50 Hz 1re/2e/3e vitesse 1st/2nd/3d gear 1ste/2e/3e snelheid	148/307/509	158/293/535	158/293/535	116/208/464
POIDS NET MACHINE NET WEIGHT MACHINE NETTOGEWICHT MACHINE	67 kg	110 kg	100 kg	250 kg
VOLTAGE VOLTAGE SPANNING	220V 1Ph 50Hz	220V 1Ph 50Hz	220V 1Ph 50Hz	220/380V 3Ph 50Hz*
OPTION RÉDUCTION DE CUVE OPTION BOWL REDUCTION OPTIE REDUCTIEKUIP et équipement - and tools - en werktuigen	✗	✓ 10 L	✓ 10 L	✓ 20 L