



**2 YEARS
WARRANTY**

Batteur-mélangeur de table
Tabletop beater-mixer
Tafelmodel klopper menger

- 5 vitesses progressives et minuterie.
- 5 variable speeds and timer.
- 5 traploze snelheden en timer.



- Base stable.
- Stable base.
- Stabiele basis.

- Outils inclus.
- Included tools.
- Inbegrepen werktuigen.



- Capot anti eclaboussure
- Anti splash lid.
- Spatdeksel.

- Machine très robuste
- Very robust machine
- Zeer robuuste machine

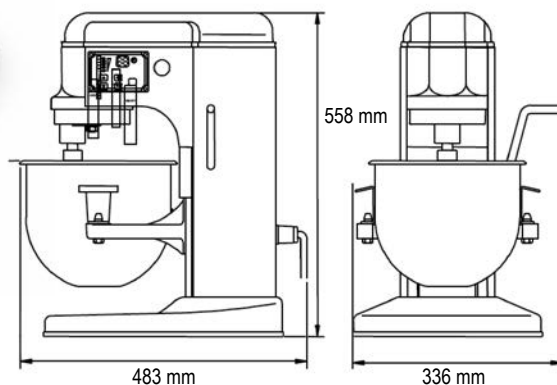

MODEL	SE10L
CAPACITÉ CUVE BOWL CAPACITY KUIPINHOUDE	10 L
VITESSE t/m RPM SNELHEID t/m	100 - 500
Max. farine Max flour Max. bloem	1 kg
POIDS NET MACHINE NET WEIGHT MACHINE NETTOGEWICHT MACHINE	20 kg
PUISSANCE POWER VERMOGEN	650 W
VOLTAGE VOLTAGE SPANNING	230V 1Ph